

Detection of Multi-Frequency Weak Signal Based on Stochastic Resonance

Chao Peng¹, En Cheng¹, HaiXin Sun¹, Guangtao Yao²

1. School of Information Science and Engineering, Key Laboratory of Underwater Acoustic Communication and Marine Information Technology Ministry of Education, Xiamen University, Xiamen, Fujian, 361005, China

2. 73111 troops Post doctoral workstation

Corresponding author is En Cheng

Abstract

There are plenty of weak audio analog signals in ocean, whose signal characteristic is usually an important basis for the target detection in ocean, therefore it is necessary to seek for approaches to detect the weak audio signal. Stochastic resonance, which is regarded as a novel method for detecting the weak signal, has been applied in many areas. However, the most researches concentrate on the single-frequency weak signal, and less research on the multi-frequency weak signal. Starting from the basic bistable stochastic resonance system, theoretical analysis on the multi-frequency analog signal with strong noise is carried out, and a method for detecting and recovering the multi-frequency analog signal is proposed, which is based on the average inversion and interpolation fitting. The analysis and simulation results present that, the multi-frequency analog signal is successfully detected and recovered in the condition that the input signal-to-noise ratio (SNR) is -22dB. Compared with the traditional filter method, the proposed method can effectively reduce the waveform distortion and phase delay of the multi-frequency signal, and it is especially suitable for the detection of multi-frequency weak signals whose frequencies are very close, which makes it possess good theoretical guidance and practical application value.

Keywords: WEAK AUDIO SIGNAL DETECTION, STOCHASTIC RESONANCE, MULTI-FREQUENCY ANALOG SIGNAL, AVERAGE INVERSION

1. Introduction

In general, the traditional methods for detecting weak signal adopt linear filtering, wavelet analysis [1], etc, in order to suppress and eliminate noise, and ultimately get the useful information. However, those methods always lose their effects in the condition that the strong noise background exists or the frequencies of useful signal and noise are very closed [2].

In 1981, the theory of stochastic resonance was proposed by the physicist Benzi in Italy and the physicist Suterz et al in USA [3], in order to explain the periodicity of earth glacier. Briefly speaking, the mixed

signal (periodic force) and noise are added to the non-linear system, which forms a cooperative effect in a certain condition. Furthermore, a part of noise energy will be converted into signal energy, which can greatly improve the output signal-to-noise-ratio (SNR) of system and then detect the weak signal. Compared with the traditional methods, the biggest difference of stochastic resonance is that it is not to suppress noise but to use noise, which opens a new perspective for the detection of weak signal.

The early studies of stochastic resonance were focused on theoretical development. The theories of

stochastic resonance are so much, such as adiabatic approximation theory, linear response theory, eigenvalue theory and so on [4]. With the continuous development of stochastic resonance in the practical applications, we have put forward more and more other theories [5-6], but these theories have the limitations. Therefore, we have carried out more researches on how to apply stochastic resonance in practice. At present, stochastic resonance has been widely applied in the fields of electronics[7], communication[8], physics[9], biology[10]and so on. Moreover, many better research results have been successfully obtained, especially in the design of cochlear hearing aid [11] and circuit[12]. However, how to apply the theory of stochastic resonance to the practice, there are still many problems. From the conventional stochastic resonance system for detecting the multi-frequency analog signals, we find that the stochastic resonance system is used to produce a response merely for a certain frequency[13]. Moreover, the recovered signal loses other useful frequency, which results in serious distortion. Aiming at this problem, we propose a stochastic resonance method to detect multi-frequency analog signals, which is combined with the average inversion and interpolation fitting. The feasibility of the proposed method is verified by simulation and data processing.

2. Stochastic resonance theory and its model

2.1. The principle of bistable stochastic resonance

Regarding the bistable system as research subject, it can be demonstrated as a stochastic differential equation, i.e., the nonlinear Langevin equation[14]:

$$\frac{dx}{dt} = ax - \mu x^3 + s(t) + \xi(t) \tag{1}$$

where, a and μ are system parameters; $s(t)$ is input signal; $\xi(t)$ is input noise, which is generally assumed as a Gaussian white noise with zero mean value, and its autocorrelation function is $\langle \xi(t)\xi(0) \rangle = 2D\delta(t)$, where $\langle \cdot \rangle$ represents the deduction of expectation operator and $\delta(t)$ represents impulse function; D represents noise intensity, i.e., unilateral power spectrum density. From the angle of mechanics, $x(t)$ can be considered as a overdamping particle trajectory passing in the bistable potential well modulated by signal, and its potential function is $U(x) = -ax^2/2 + \mu x^4/4 - s(t)x$ and the barrier height is $\Delta U = a^2/(4\mu)$. Due to the stochastic effect of noise on the particle and the modulation of weak signal on potential well, the system output will achieve a cooperative state under the certain optimal noise intensity.

2.2. Model analysis and improvement

In a shorter time, the signal $s(t)$ can be considered as a constant h . Subsequently, based on $y = x/\sqrt{D}$, $\bar{u} = uD$ and $\bar{h} = h/\sqrt{D}$, Eq. (1) can be further transformed, and a new bistable system model is obtained as follows:

$$dy/dt = ay - \bar{u}y^3 + \bar{h} + \Gamma(t) \tag{2}$$

The FPK equation of the output probability density of the system (2) is:

$$\frac{\partial \rho(y,t)}{\partial t} = -\frac{\partial}{\partial y}[c(y)\rho(y,t)] + \frac{\rho^2(y,t)}{\partial y^2} \tag{3}$$

At this time, we define functions as follows:

$$f_i(\bar{u}, \bar{h}) = \int_{-\infty}^{+\infty} y^i \exp[g(y)]dy, i = 0, 1, 2, \dots \tag{4}$$

$$g(y) = \frac{1}{2}ay^2 - \frac{1}{4}\bar{u}y^4 + \bar{h}y \tag{5}$$

According to Eqs. (4)-(5) and the FPK equation of the output probability of bistable system, we can get the output SNR equation of system, which is shown as follows:

$$SNR_{out} = D \left\{ \frac{f_2(\bar{u}, \bar{h})}{f_0(\bar{u}, \bar{h})} - \frac{f_1^2(\bar{u}, \bar{h})}{f_0^2(\bar{u}, \bar{h})} \right\} \tag{6}$$

As can be seen from Eq.(6), it is very troublesome to adopt the concept of output SNR. Moreover, this formula also reflects the deficiency of adiabatic approximation theory. That is, when the noise is zero, the output SNR is also zero, which is not consistent with the actual situation that the output SNR tends to infinity. As a result, we introduce the system response rate to explain the generation mechanism of stochastic resonance. The system response rate reflects the ability of system to follow the change of the signal, and it's reciprocal is the system characteristic time. i.e., the main time scale that the system output probability density tends to the asymptotic solution. The formula is shown as follows:

$$\lambda = \frac{\int_{-\infty}^{+\infty} \{[\frac{1}{2}g''(y) + \frac{1}{4}g'^2(y)]u^2(y) + u'^2(y)\}dy}{\int_{-\infty}^{+\infty} u^2(y)dy} \tag{7}$$

Note that, the system response speed proposed here is quite different from the traditional linear response speed. The variational method, used in the calculation of system response speed, can convert Eq. (7) into $(K - \lambda M)d = 0$, where K is a semi-positive definite symmetric matrix and M is a positive definite symmetric matrix. Then, we calculate the generalized eigenvalues, which are all greater than or equal to 0. As a result, the minimum value must be 0 and

we select the second small positive value as the system response speed. Fig. 1 shows the relationship between the system response speed and parameter u' .

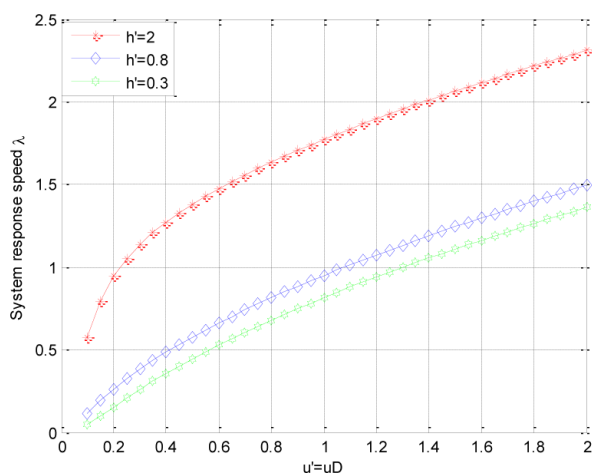

Figure 1. The relationship between u' and system response speed

3. The detection of weak signal

3.1 The detection of single-frequency signal

Single-frequency analog signal is the most simple application of stochastic resonance, and it also possesses enough capability to reflect the ability of stochastic resonance to enhance the signal output SNR by using noise. Assume the input signal is $S = 0.3\sin(0.2\pi t)$, where the system parameters are $a = 1$ and $u = 1.3$, the noise intensity is $D = 10$, the sampling frequency is $f_s = 5\text{Hz}$. As can be seen from Fig. 2, when the noise intensity is 10, the measured signal cannot be found by using the usual spectrum method. Fig. 3 shows the spectrum curve of output system, and we can find that there is a sharp peak at $f=0.1\text{Hz}$, which indicates that the stochastic resonance system greatly improves the output SNR. Moreover, according to the comparison of Figs. 2-3, we can see that the stochastic resonance system makes the whole spectrum of mixed signal transfer to the low frequencies, which is also the reason of the enhancement of the SNR of output signal.

Because the adjustment of the parameter or the noise intensity has the same effect, we fix $u = 0.1$ and $D = 5$, and then adjust parameter a from 0.1 to 5. In general, we use the output SNR as an index to measure the degree of resonance, where SNR is defined as the ratio of signal power at the measured frequency point and the remainder total power except for this frequency point:

$$SNR_{out} = 10 \times \log_{10} \left(\frac{P_{signal}}{P_{noise}} \right) \quad (8)$$

where, P_{noise} is the noise power, and it is obtained by calculating the average of noise powers in a cer-

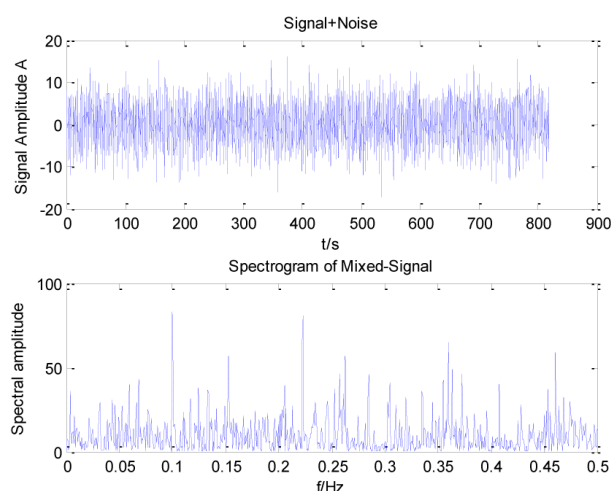

Figure 2. Time-domain curve and frequency-domain curve of mixed signal

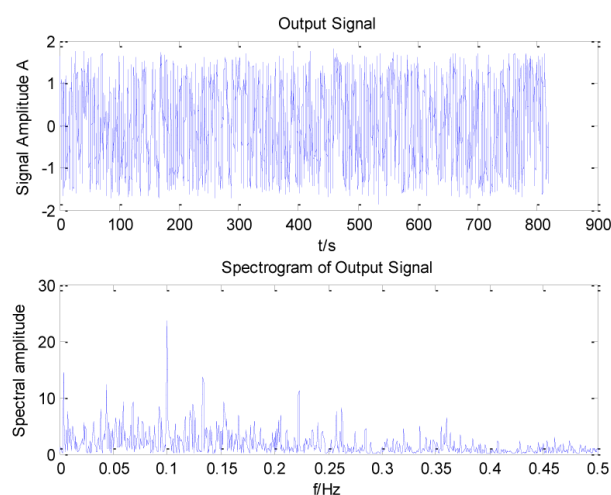

Figure 3. Time-domain curve and frequency-domain curve of output signal

tain scope of corresponding signal frequency. However, because of the randomness of stochastic resonance system, it is not tenable to use the output SNR as the index to measure the degree of resonance. Subsequently, in this paper, we use the SNR gain as the index to measure the strength of stochastic resonance:

$$SNR_{gain} = \frac{SNR_{out}}{SNR_{in}} \quad (9)$$

As can be seen from Fig. 4, when u is gradually increased, the SNR gain first presents monotonic rise, and then monotonous decline, from which we can see the obvious stochastic resonance phenomenon by adjusting parameter. Moreover, the curve is not smooth, which is resulted from the random property of stochastic resonance.

3.2. The detection of multi-frequency signal

For the multi-frequency analog signal in practical application, we still use the above-mentioned

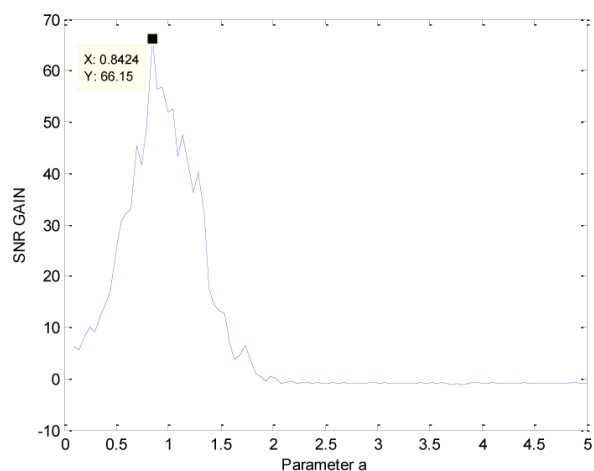

Figure 4. Curve of SNR gain of single-frequency weak signal changing along with system parameter a

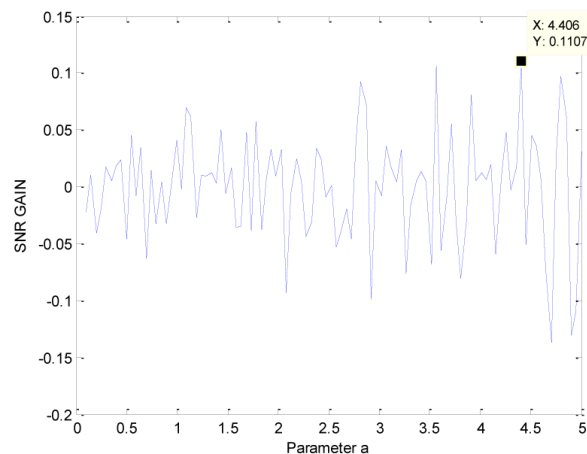

Figure 5. Curve of SNR gain of multi-frequency weak signal changing along with system parameter a

bistable stochastic resonance system to code with it. Assume that there is a multi-frequency analog signal $S = 0.3\sin(0.2\pi) + 0.2\sin(0.5\pi)$ with $D = 5$ and $u = 0.1$. Then, we can get Fig. 5 by adjusting parameter a.

From Figure 5, it is found that the SNR gain of the multi-frequency signal has presented a chaotic change along with the change of system parameter a, which reflects that the stochastic resonance system is not effective. Then, we take the peak of Fig. 5 as the system parameter, and observe the time-domain and frequency-domain figures of output signal. As can be seen from Fig. 6, it is not possible to recognize the multi-frequency components from the frequency spectrum, which has been processed by stochastic resonance system, At this time, the noise in high frequency band is shifted to low frequency band, which means that the stochastic resonance system is completely ineffective.

4. The detection and recovery of multi-frequency signal

4.1. Theory analysis

After that the signal is processed by stochastic resonance system, it is still a stochastic process. Here, the statistical mean of system output is regarded as the output signal, and the probability density and the digital features of system output are studied. The formula of output mean is[15]:

$$E[x] = \sqrt{D} f_1(\bar{u}, \bar{h}) / f_0(\bar{u}, \bar{h}) \quad (10)$$

We can obtain the amplitudes of different input signals and the corresponding output values in advance, therefore we can use Eq. (10) to establish the nonlinear inversion relationship between the input and output signals.

Before the inversion is used, we take the average of 9 points. After the subsequent inversion, interpo-

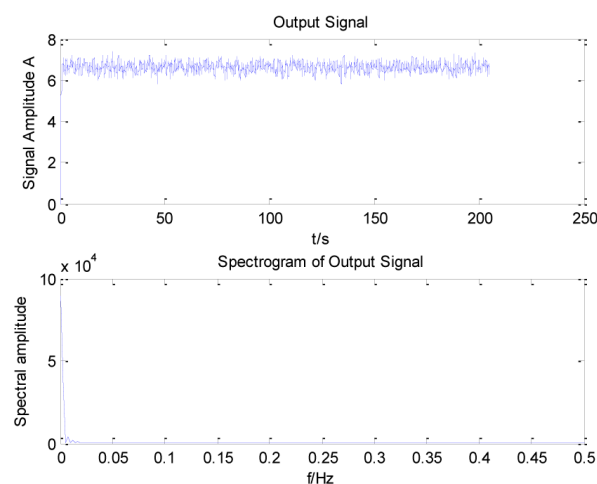

Figure 6. The stochastic resonance of multi-frequency signal

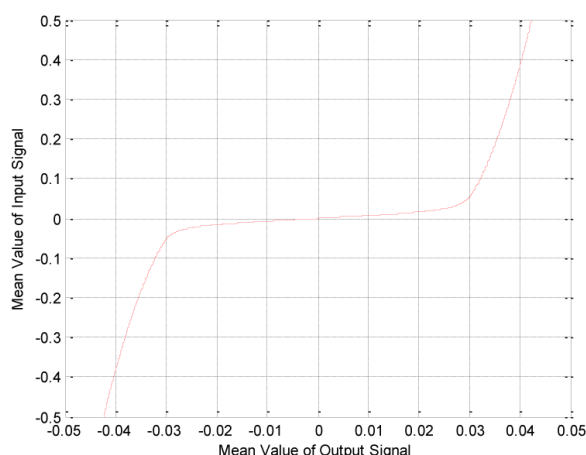

Figure 7. The chart of inversion relationship

lation and fitting are carried out by using piecewise Hermite, and the recovery signal is obtained finally. Here, the operation of average also reduces the randomness of the stochastic resonance system.

4.2. Simulation analysis

Stochastic resonance system adopts Simulink simulation, and the simulation system is illustrated by Fig. 9.

The test input signal is chosen as $S = 0.3\sin(0.2\pi) + 0.2\sin(0.5\pi)$, and the input SNR is -22dB. After the nine-point average treatment on the output signal of stochastic resonance system, we choose 18 points in every period, and then recover the input signal about the corresponding point by us-

ing the inversion formula. Finally, the input signal recovered by interpolation and fitting is illustrated by Fig. 10.

In Figure 10, the low-pass filter is a 8-order Butterworth low-pass filter, whose cutoff frequency is 1Hz. From the treatment results, the treatment results of stochastic resonance are better than those of low-pass filter, which can effectively reduce the waveform distortion and phase delay of multi-frequency signal. However, due to the nonlinear characteristics

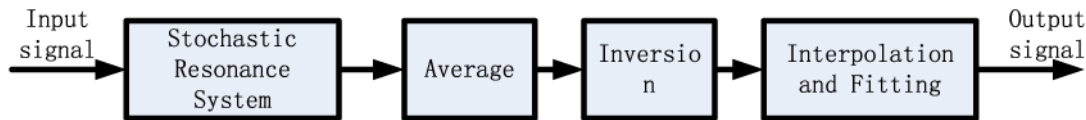

Figure 8. The block diagram of inversion relationship

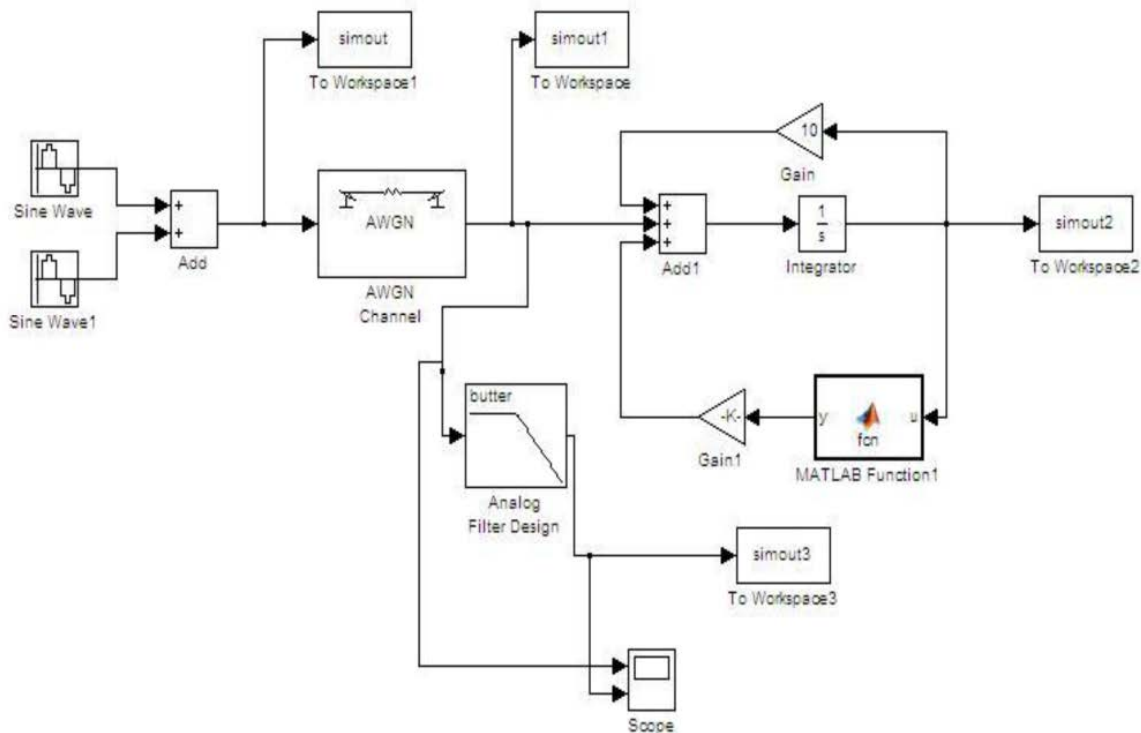

Figure 9. Stochastic resonance system adopts Simulink simulation

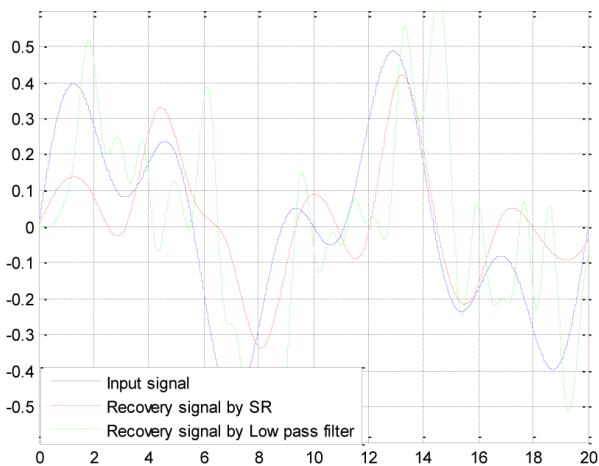

Figure 10. The input signal recovered by interpolation and fitting

of stochastic resonance system, the treatment results of stochastic resonance always exist distortion. Moreover, by means of observing the curves in figure, we can find that the more fast the signal changes, the more serious the distortion is. But on the whole, the recovery signal can follow the change trend of the original signal, which lays a solid foundation for the subsequent detection of multi-frequency weak signal. According to the recovery signal, we make the spectrum graph as shown in Fig. 11.

From Fig. 11, it can be seen that the frequency spectrum of the recovery signal has two distinct peaks at 0.1Hz and 0.25Hz. Therefore, we successfully detect and recover the multi-frequency weak signal. Moreover, we can also see that this method

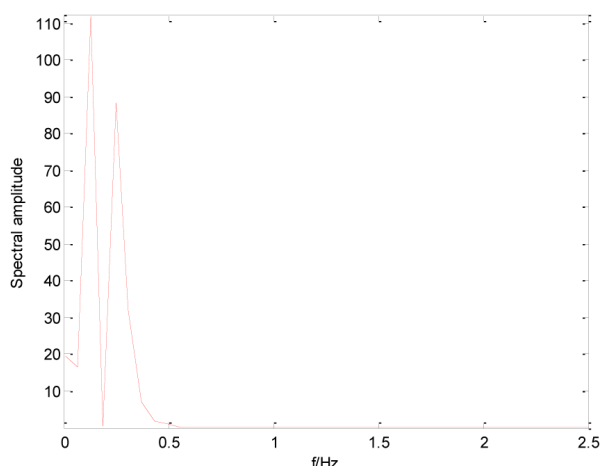

Figure 11. The spectrum graph

is particularly suitable for the detection of multi-frequency weak signal, whose frequencies have small deference.

Conclusions

Starting from the theoretical analysis of stochastic resonance system, this paper analyzes the deficiencies and shortcomings of conventional stochastic resonance methods in the detection of multi-frequency weak signal. Then, a solution method is put forward by combining stochastic resonance, average inversion and interpolation fitting. Simulation results show that, compared with the traditional filter method, the proposed method can effectively reduce the waveform distortion and phase delay of the recovered signal, and it is quite suitable for the detection of multi-frequency weak signals whose frequencies are very close. This method has a certain theoretical value, and also has great practical application value, which lays a solid foundation for the subsequent detection of marine targets.

Acknowledgements

This work was supported by the National Natural Science Foundation of China (61471309, 61107023), Ph.D. Programs Foundation of Ministry of Education of China (20110121120020), the Fujian Natural Science Foundation of China (2010J01344, 2013J01258), and the key project in Fujian Province (2012H 1012).

References

- Deng H-G, Cao W-H, Yang B-C, Mei W-P, Ao B-Q. Weak periodical signal detection based on wavelet threshold de-noising and chaos theory [J]. *Zhongnan Daxue Xuebao (Ziran Kexue Ban)/Journal of Central South University (Science and Technology)*. 2012,43(5):1773-9.
- Zhu S, editor Study on weak signal detection methods. 2nd International Conference on Green Communications and Networks, GCN 2012, December 12, 2012 - December 14, 2012; 2013; Chongqing, China: Springer Verlag.
- Benzi R. Stochastic resonance: from climate to biology [J]. *Nonlinear Processes in Geophysics*. 2010,17(5):431-41.
- Rousseau D, Chapeau-Blondeau F, editors. Stochastic resonance and improvement by noise in optimal detection strategies 2005: Elsevier Inc.
- Addesso P, Pierro V, Filatrella G. Interplay between detection strategies and stochastic resonance properties. *Communications in Nonlinear Science and Numerical Simulation*. 2016;30(1-3):15-31.
- Chen XH, Cheng G, Shan XL, Hu X, Guo Q, Liu HG. Research of weak fault feature information extraction of planetary gear based on ensemble empirical mode decomposition and adaptive stochastic resonance. *Measurement*. 2015;73:55-67.
- Djurhuus T, Krozer V. A Generalized Model of Noise Driven Circuits with Application to Stochastic Resonance. *Ieee Transactions on Circuits and Systems I-Regular Papers*. 2015;62(8):1981-90.
- Li JM, Chen XF, He ZJ. Multi-stable stochastic resonance and its application research on mechanical fault diagnosis. *Journal of Sound and Vibration*. 2013;332(22):5999-6015.
- Chizhevsky VN. Noise-induced suppression of nonlinear distortions in a bistable system with biharmonic excitation in vibrational resonance. *Physical Review E*. 2015;92(3):7.
- McDonnell MD, Iannella N, To MS, Tuckwell HC, Jost J, Gutkin BS, et al. A review of methods for identifying stochastic resonance in simulations of single neuron models. *Network-Computation in Neural Systems*. 2015;26(2):35-71.
- Martignoli S, Gomez F, Stoop R. Pitch sensation involves stochastic resonance. *Scientific Reports*. 2013;3:9.
- Yu H, Guo XM, Wang J, Liu C, Deng B, Wei XL. Adaptive stochastic resonance in self-organized small-world neuronal networks with time delay. *Communications in Nonlinear Science and Numerical Simulation*. 2015; 29(1-3):346-58.

13. Zhang JJ, Zhang T. Parameter-induced stochastic resonance based on spectral entropy and its application to weak signal detection. *Review of Scientific Instruments*. 2015;86(2):6.
14. He MJ, Xu W, Sun ZK, Du L. Characterization of stochastic resonance in a bistable system with Poisson white noise using statistical complexity measures. *Communications in Nonlinear Science and Numerical Simulation*. 2015;28(1-3):39-49.
15. Liu SJ, Yang T, Zhang XZ. Effects of stochastic resonance for linear-quadratic detector. *Chaos Solitons & Fractals*. 2015;77:319-31.



Digital Circuit Optimization Design Algorithm Based on Cultural Evolution

Xuesong Yan¹, Qinghua Wu^{2,3}, Hanmin Liu⁴

¹*School of Computer Science, China University of Geosciences, Wuhan, Hubei, 430074, China*

²*Hubei Provincial Key Laboratory of Intelligent Robot, Wuhan Institute of Technology, Wuhan, Hubei, 430073, China*

³*School of Computer Science and Engineering, Wuhan Institute of Technology, Wuhan, Hubei, 430073, China*

⁴*Wuhan Institute of Ship Building Technology, Wuhan, Hubei, 430050*

**Corresponding author*

Corresponding author is Qinghua Wu

Abstract

Cultural Algorithms (CA) are a class of computational models derived from observing the cultural evolution process in nature. The Cultural Algorithm is a dual inheritance system that characterizes evolution in human culture at both the macro-evolutionary level, which takes place within the belief space, and at the micro-evolutionary level, which occurs at the population space. Cultural algorithm is used to solve complex calculations of the new global optimization search algorithms, cultural algorithms in the optimization of the complex functions of its superior performance. In this paper, we use the this algorithm for combinational digital circuit optimization design, from the experiment results shown our algorithm are effective for this problem.

Keywords: COMBINATIONAL DIGITAL CIRCUIT, CULTURAL ALGORITHM, CIRCUIT OPTIMIZATION DESIGN, CIRCUIT EVALUATION